

POS. No.	Ref.No.	Description	POS. No.	Ref.No.	Description
----------	---------	-------------	----------	---------	-------------

1	157841	Pneumatic actuator OBER
2	158353	Adaptor
50	155254	Console
51	361280	Screw M 4x6
52	361277	Washer 1-M4
53	179620	Adaptor
54	361273	Screw M6X6 DIN 913
55	151272	Strip
58	179631	Shaft
59	179627	INNER PROTECTIVE PIPE SET
60	361288	Screw M 6x30 ISO7380
61	179649	Washer
62	361288	Screw M 6x30 ISO7380
63	179613	Stoppie
64	179611	Pipe
65	179614	Bush
66	179645	Bush
67	179647	Handle set
68	361269	Screw M 6x60 ISO7380
69	155669	Support
70	361271	Screw M 6x16 ISO7380
71	179609	Spacer washer
72	179610	Washer
73	361267	Special nut M6
74	179614	Bush
75	155987	Pipe L645
77	179630	OUTER PROTECTIVE PIPE SET
78	155246	Space bush
79	361320	Screw M 8x20 FABORY 07141080025 M Zn A3A
80	361291	Screw C1-M4x30
81	361294	Screw C1-M4x35
82	155255	Adaptor
83	155293	Hose L400
84	179674	Lever set
85	179658	Adaptor
86	330330	O-ring 31X2B
90	361136	Pin Ø3x8 DIN7343
91	179644	Lock button
92	115165	Spring
93	179642	Bearing Bushing
94	155287	Console
95	179625	Space bush
96	361265	Screw M6X42 DIN 427
97	179652	Enclosure
98	330483	Circlip B12
99	331319	Washer AS1528

100	331318	Bearing AXK 1528
101	331319	Washer AS1528
102	179641	Space bush
103	330820	Bearing 2RSR
104	330608	Gasket AS15x28x7 NBR
105	330588	Circlip A28
106	155258	Spindle
107	179628	Spring
108	155285	Protective cover Ø220
109	330486	Circlip B35
110	155294	Brush
111	155295	Gasket
112	155296	Collar
113	156570	Bush
114	121838	Locking nut
117	361319	Screw M 8x20 FABORY 07141080020 M Zn A3A
118	184121	Dust Extraction Adaptor
122	361323	Screw M 6x8 ISO7380
125	155989	Disk
126	179741	Disk
127	155991	Disks set 200mm
130	141966	Depth gauge
131	361350	Screw C1-M5x8
132	360078	Spring washer 5H
133	361353	Nut M5 ISO 10511 Zn
134	159541	Service pack
201	157858	Operating instruction
202	155995	Packaging

SM 15

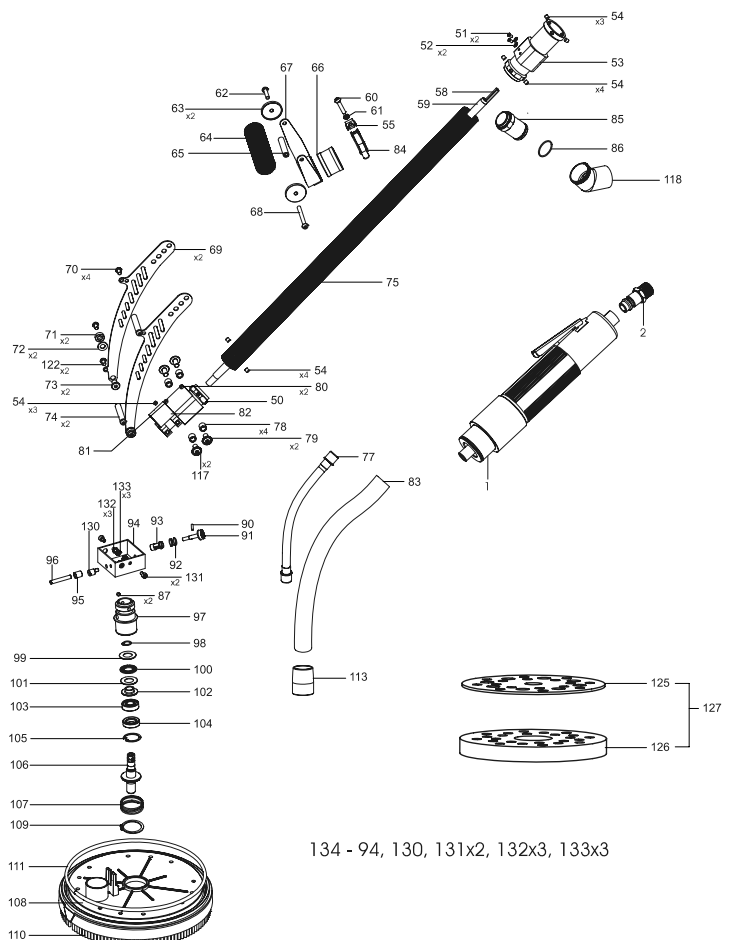

134 - 94, 130, 131x2, 132x3, 133x3

